

# UNLEADED FUEL LANTERN (282) LANTERNE A ESSENCE

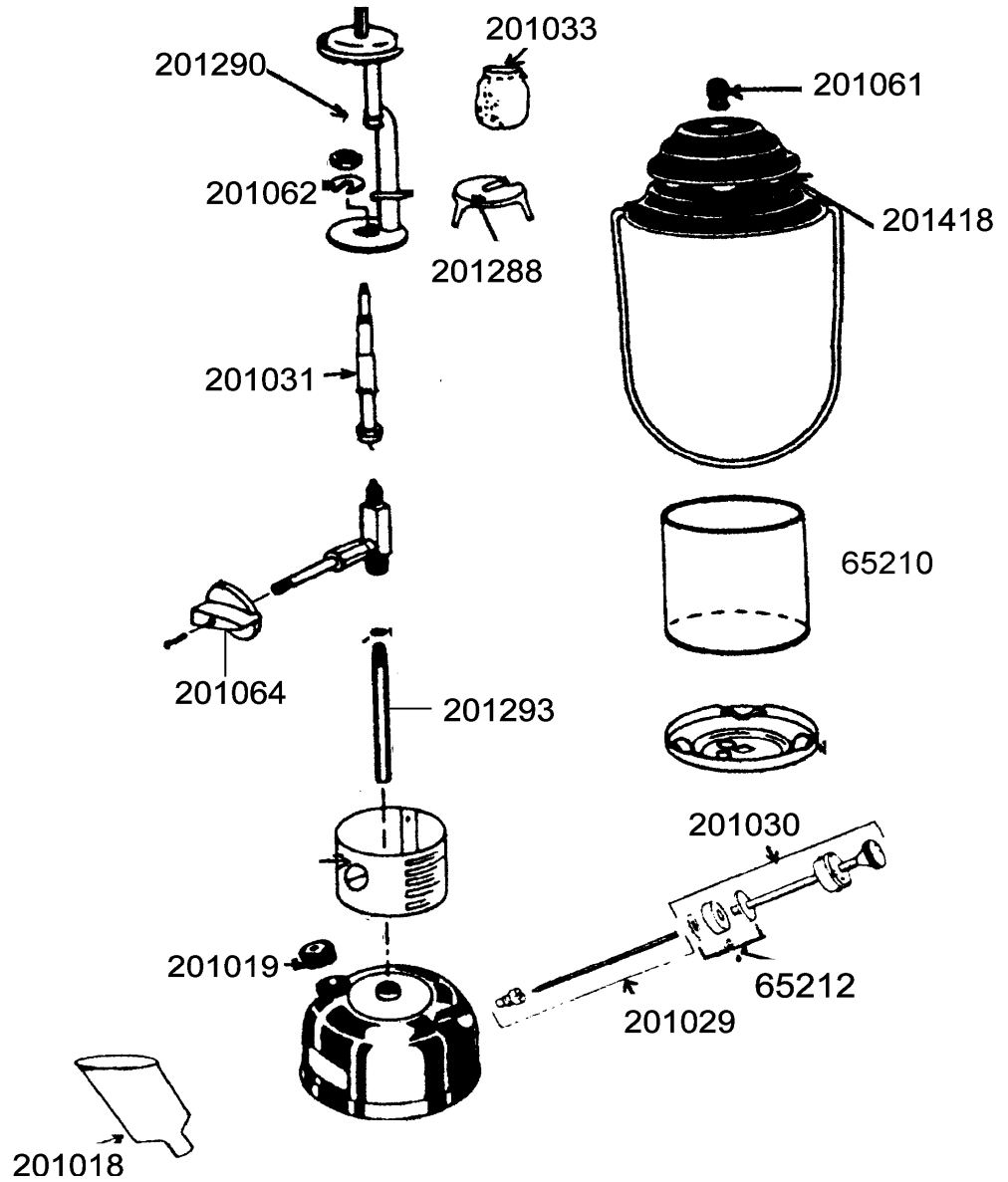

REF.	POINTS	GB DESIGNATIONS	DESIGNATIONS F
65210	110	GLOBE DIAMETER 110	VERRE DIAMETRE 110
65212	80	PUMP CUP & CLIP (BLISTER PKG)	JOINT PISTON POMPE (BLISTER)
201018	60	FILTER FUNNEL	ENTONNOIR
201019	70	FILLER CAP	BOUCHON DE REMPLISSAGE
201029	50	AIR STEM & CHECK VALVE	ENSEMBLE CLAPET DE RETENUE
201030	100	PUMP PLUNGER (OLD&CURRENT MOD)	PLONGEUR POMPE(ANCIEN&ACTUEL)
201031	110	GENERATOR	GENERATEUR
201033	45	MANTLE (X2)	MANCHON (X2)
201061	50	CAP SCREW (X2)	ECROU CHAPEAU (X2)
201062	40	U CLIP	ATTACHE EN U
201064	50	KNOB & SCREW	VOLANT & VIS
201288	40	HEAT SHIELD	PARE CHALEUR
201290	150	BURNER ASSEMBLY	ENSEMBLE BRULEUR
201293	50	FEED TUBE ASSEMBLY	ENSEMBLE TUBE ALIMENTATION
201418	160	CAP & BAIL	CHAPEAU + ANSE